

Maestro 30

Electro-mechanical 2-post lift, 3 t capacity



Application

- Repair and maintenance

Approvals / recommendations

- Volkswagen Group
- Volvo

Description:

Posts:

- Asymmetric post installation
- Very stable bent posts
- Without base frame
- Two motors
- Cold-rolled spindle
- Nylon nut sets
- Carriage with slide blocks
- Pushbutton control unit with alarm signal
- Programmable top stop
- Electronic synchronization

Arms:

- Single telescopic front and rear arms, as standard
- Possibility of parallel parking of arms
- Internal arm locking system
- Low minimum height

Standard colours:

- Arms: RAL 3020 – red
- Posts: RAL 7016 – grey

Versions:

- Available with different voltages
- F = flex pad
- CF = combiflex pad
- CF-08 = combiflex 08 pad
- DT/- = double telescopic short arms, single telescopic long arms

Optional extras:

- Available with 2 different portal heights; alternatively in-ground kit
- LED-lighting set
- Power pack
- Set of expansion bolts
- Extra control unit
- Large program of extra pads

Special colours available on request!



Scan the QR-Code for detailed product information.

Further Information on www.autopstenhoj.com

autop Maschinenbau GmbH

Sandkampstraße 90
D-48432 Rheine

☎ +49 5971 8602-02

☎ +49 5971 8602-25

✉ info@autopstenhoj.com

STENHØJ A/S

Barrit Langgade 188-190
DK-7150 Barrit

☎ +45 76 82 13 30

☎ +45 76 82 13 31

✉ info@autopstenhoj.com

Technical data

Lifting capacity	3,000 kg
Lifting height	1,900 mm
Working height	1,995 – 2,025 mm
Lifting / lowering time	approx. 40 sec.
Motor	2 x 2.8 kW
Voltage	3 x 230/400V – 50 Hz – 25/16 A

Arm superstructure

Lifting pad included in the delivery	F: 777112 (30 – 60 mm) CF: 777539 CF-08: 777395 + 660501
Min. height	95 mm
Drive-through width	2,110 – 2,310 mm
Width between posts	2,365 – 2,565 mm
Total width - outer edges posts	2,875 – 3,075 mm
Total width - outer edges base plates	3,120 – 3,320 mm
Total height post	2,706 mm
Total height incl. portal	4,050 / 4,350 mm
Arm length front, min. - max.	F Std: 540 – 850 mm F DT: 480 – 840 mm
Arm length rear, min. - max.	900 – 1,425 mm

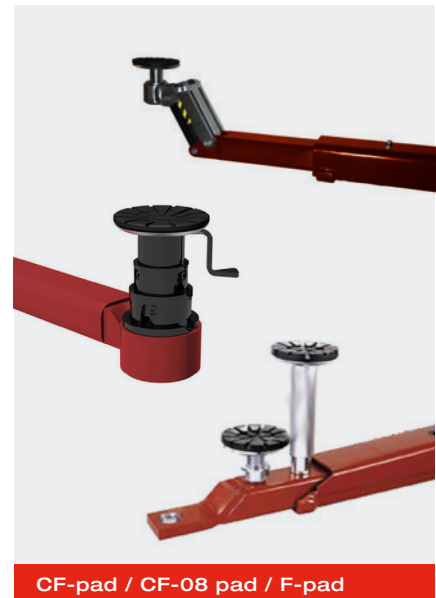
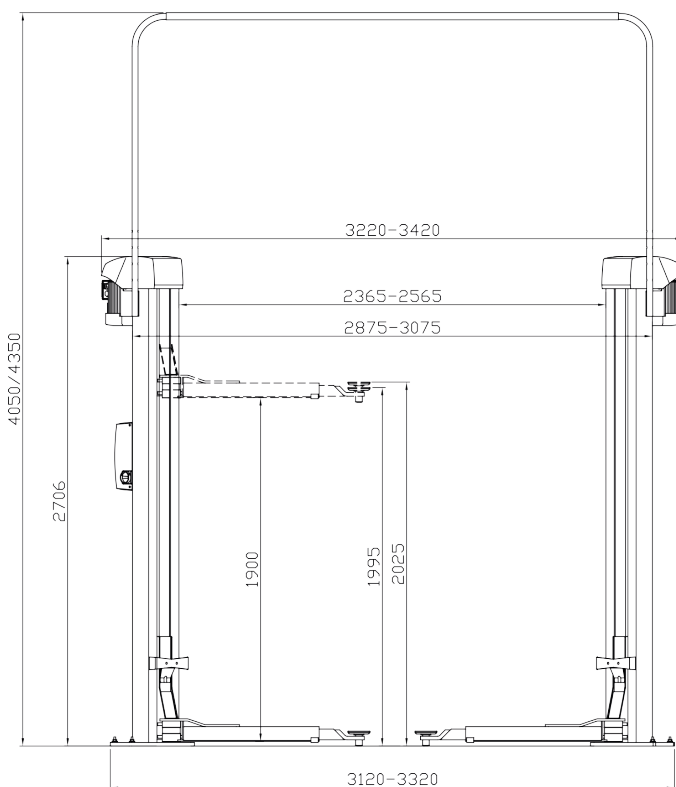

CF-pad / CF-08 pad / F-pad



Internal arm locking system