





**GT - SBSP 1000**

# SOLLEVATORE MOBILE PER BATTERIE

-  Sollevatore mobile per batterie a doppia forbice
-  Mobile battery lift with double scissors
-  Mobiler Lifter für Batterien mit Doppelschere
-  Elévateur mobile pour batteries à double ciseaux
-  Elevador móvil para baterías con doble tijera

**1.000**  **Kg**



**MOVIMENTO  
PNEUMATICO:  
SOLLEVAMENTO  
VELOCE E  
SENZA FATICA**



DATI TECNICI	TECHNICAL DATA	TECHISCHE DATEN	DONNÉES TECHNIQUES		
Portata max.	Max. capacity	Max. Tragfähigkeit	Portée max.	kg	1000
Tempo di salita / discesa	Lifting / lowering time	Hubfahrt-/ Senkfahrdauer	Temps de montée / descente	s	35/20
Alimentazione	Power supply	Stromversorgung	Alimentation		in 6/8 bar (120 on working)
Peso totale	Total weight	Gesamtgewicht	Poids total	Kg	385
Altezza sollevamento	Lift height	Höhe Aufzug	Altura ascensor	mm	630-1700
Tensione circuito comandi	Circuit voltage command	Leerlaufspannung Befehl	Circuit de commande de tension	V	--



PONTI SOLLEVATORI  
ATTREZZATURE PER OFFICINE

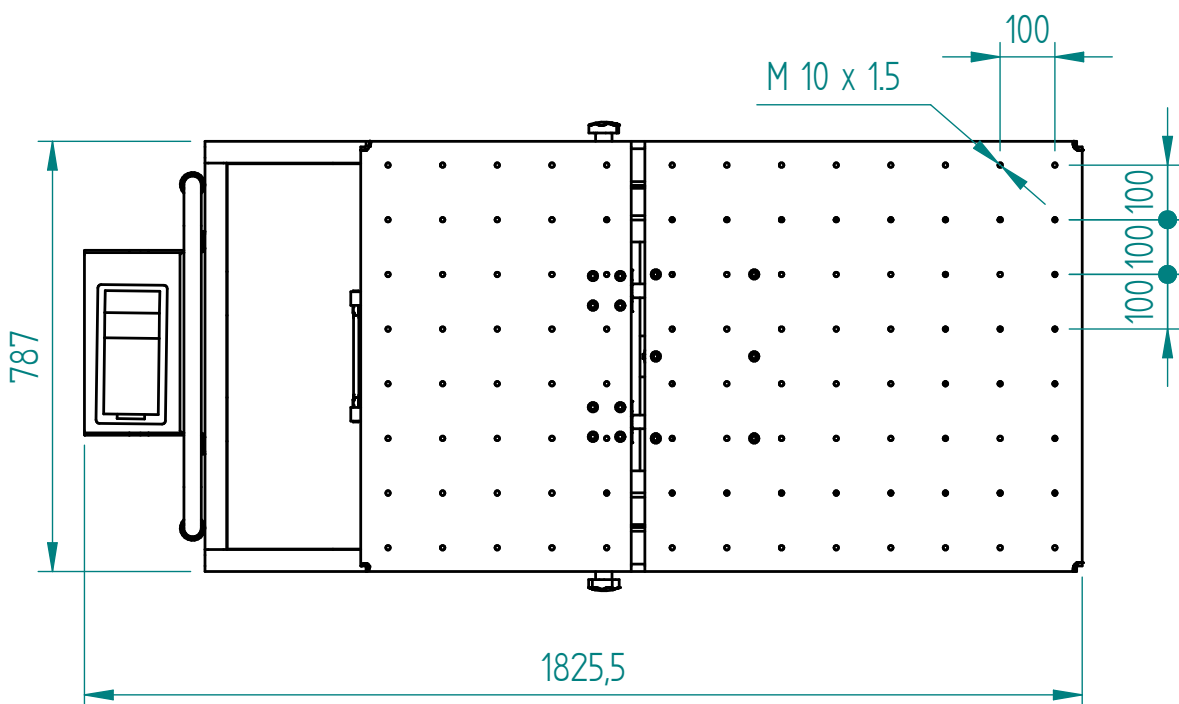
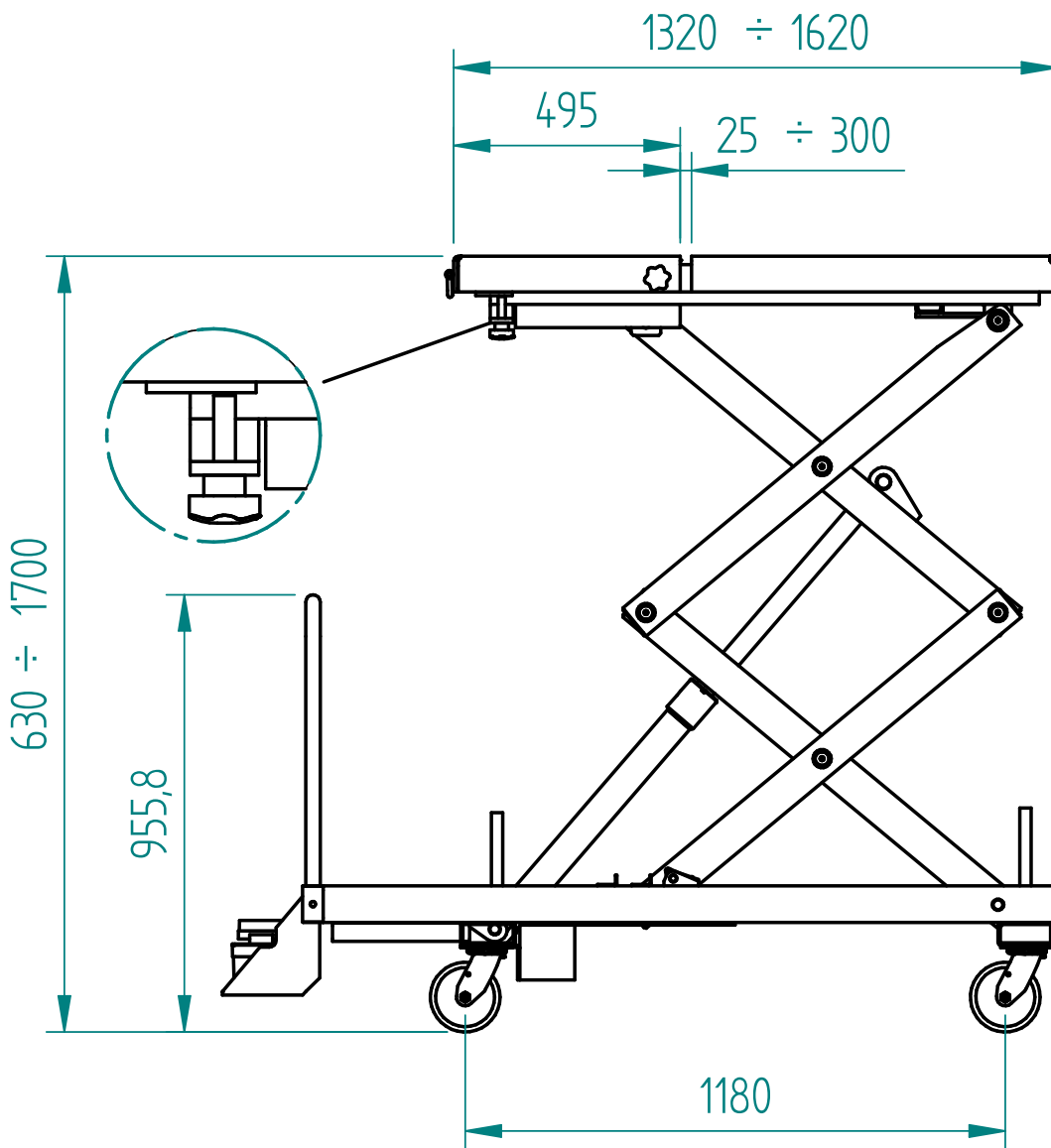

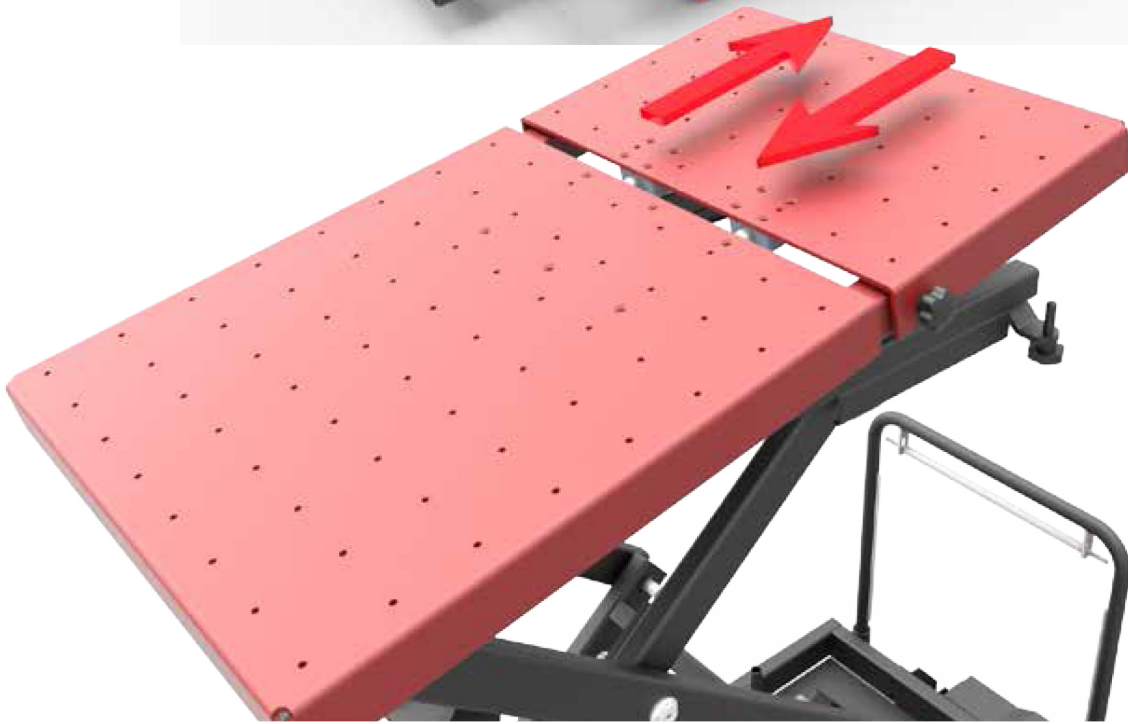





PONTI SOLLEVATORI  
ATTREZZATURE PER OFFICINE



## MECHANICAL SAFETY LOCK WITH MANUAL RELEASE SICURA MECCANICA CON SGANCIO MANUALE

- 
  - Adatto e pratico per sollevare motori auto / cambi / batterie.
  - Il sollevatore ha la copertura traslante con possibilità di aprirsi e permettere all'operatore di avere lo spazio per sganciare la batteria della vettura comodamente.
  - il movimento del ponte è pneumatico
- 
  - Geeignet und praktisch zum Heben von Automotoren / Getrieben / Batterien.
  - Der Aufzug hat eine Übersetzungsabdeckung mit der Möglichkeit, den Mechaniker Platz zu geben, um die Autobatterie bequem freizugeben.
  - Die Bewegung der Brücke ist pneumatisch
- 
  - Adecuado y práctico para levantar motores de automóviles / cajas de cambios / baterías.
  - El puente tiene una plataforma que se abre y permite que el operador tenga espacio para liberar la batería del automóvil cómodamente.
  - El movimiento del puente es neumático.
- 
  - Suitable and practical for lifting car engines / gearboxes / batteries for electric or hybrid cars.
  - The lift has a translating cover with the possibility of opening and allowing the operator to have space to release the car battery comfortably.
  - the movement of the lift is pneumatic.
- 
  - Convient et pratique pour soulever les moteurs / boîtes de vitesses / batteries de voiture.
  - Le pont a une plate-forme qui s'ouvre et permet à l'opérateur d'avoir suffisamment d'espace pour libérer la batterie de la voiture confortablement
  - le mouvement du pont est pneumatique

## BATTERY LIFTS CAN BE USED FOR SEVERAL USE INSTALLING GEAR BOX - ENGINES - BATTERY

